



INSTRUCTION MANUAL and WARRANTY REGISTRATION CARD



IRM SERIES

INDUSTRIAL RACK MOUNT

SINWAVE INVERTER

Latronics P.O. Box 73 Moffat Beach Qld 4551 AUSTRALIA

Ph 61 7 5491 6988

web: www.latronics.com.au

email: technical@latronics.com.au



**LATRONICS
P.O. BOX 73
MOFFAT BEACH QLD 4551
AUSTRALIA**

**Please
Affix
Stamp
Here**

WELCOME

Latronics products are all proudly designed, engineered and manufactured in Australia. As a specialist Sine Wave Inverter company we produce Inverters for a diverse range of applications such as; mining, railways, telecommunications, marine, remote power, motor homes, and other industrial or commercial installations.

In order to produce the most reliable products available, *Latronics* Inverters have been designed to endure the most rugged terrain and the harshest conditions across the Australian continent.

All products are engineered using the latest high quality components and manufactured to stringent quality standards, thus ensuring *Latronics* customers all enjoy many years of trouble free operation.

It is important to us at *Latronics*, that our clients enjoy the maximum benefits from our Inverters, in a safe and productive environment. Thus we strongly advise that you read through the next few pages of this manual, which explains all the modes of operation and relevant safety precautions for your new Power Inverter.

Please remember to complete and return your registration card or complete the online registration to validate your 3-year warranty.
Please retain your receipt as proof of purchase.

LATRONICS
PO BOX 73
MOFFAT BEACH Q 4551
PH: 61 7 5491 6988 FAX: 61 7 5491 6792
EMAIL: technical@latronics.com.au
WEB: www.latronics.com.au

IMPORTANT !

As an environmentally conscious customer you may choose to Register online at <http://latronics.com> . Once completed online, there is no need to post this registration card.

Serial No..... Date card returned.....



REGISTRATION CARD

Your warranty is only valid if this card or online registration is completed within 3 months of the date of purchase.

Name:.....Post code:.....Serial No:.....

Date of Purchase:.....Supplier:.....Model No.....

Email / Phone (optional):.....Comments:.....

- * Where is your Inverter being used? Residential Commercial
- * What Energy Source is connected to your Inverter? Solar Batteries Wind Other
- * Was your decision made because of?
Features Value for Money Appearance Recommendation Warranty Australian Made
- * How do you rate the service from your supplier? Fair Good Very Good Excellent
- * Did your new Inverter meet your expectations? Above Expectations Yes No

INVERTER EFFICIENCY & OUTPUT WAVEFORM

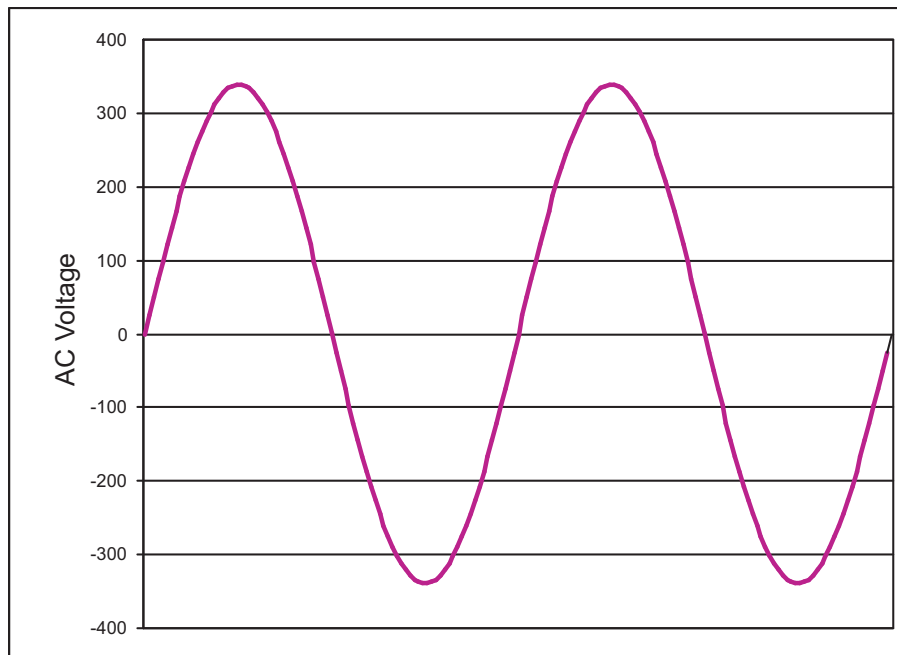
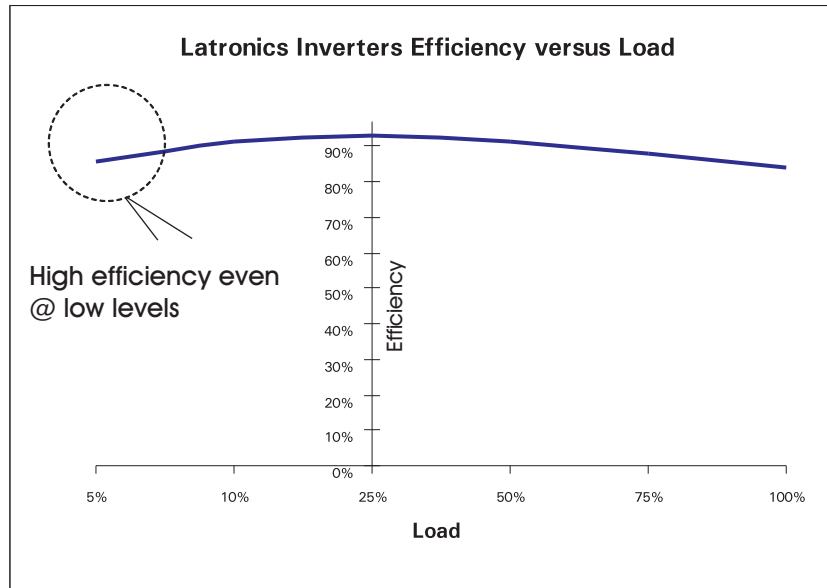

20

TABLE OF CONTENTS

PAGE

INSTALLATION

2

BATTERIES

3

DIP SWITCH SETTINGS

4

AUTOMATIC RESET FEATURE

5

AC TRANSFER SWITCH

6

SPECIFICATIONS

8

INVERTER OPERATION

10

SAFETY & AC WIRING

12

INVERTER WIRING & CONNECTIONS

13

MISCELLANEOUS OPTIONS

14

FAULT FINDING

18

WARRANTY CONDITIONS

19

INVERTER EFFICIENCY & OUTPUT WAVEFORM

20

WARRANTY CARD

21



1

INSTALLATION

- Ensure the Inverter has not been damaged in transit.
- The unit must be placed in a well-ventilated and protected area, not exposed to the open environment, and free from contaminants (i.e. Exhaust gases, sea air, battery gases, dust).

DC WIRING

- For best performance, the unit should be placed as close as possible, but not directly on top of the battery supply.
- The Inverter DC input voltage is stated on the identification label of the Inverter. Check that it is the same voltage as the battery supply.
- The Inverter is designed to operate on a battery supply only.
- The Inverter is fitted with a circuit breaker in line with the battery positive lead, which negates the need for a battery fuse.
- Ensure the Inverter is switched OFF before connecting the DC supply. Turn the circuit breaker switch to the OFF position.
- Connect the Inverter DIRECTLY to the battery terminals for best Performance.
- Input leads marked RED = (positive), & BLACK = (negative).

* *Note*:- The DC input is electrically isolated from the AC output and either the battery positive or negative can be earthed.

OBSERVE POLARITY

NOTE: Cables connecting the Inverter to the battery are designed to achieve maximum efficiency and output power:

DC CABLES SHOULD NOT BE EXTENDED

WARRANTY TERMS AND CONDITIONS FOR AUSTRALIA

Latronic Sunpower Pty Ltd ("Latronics") provides the original purchaser of a Latronics product ("You") with the following Limited Warranties as set out in this warranty certificate, in addition to your rights and remedies under consumer law. The Limited warranty periods of this inverter is 3 years. In all circumstances Latronics products are guaranteed from the date of purchase.

Part 1 - Warranty Descriptions

Latronics warrants to You that our products are guaranteed against defects in material or workmanship, when in normal use and service.

What you must do

1. For a Limited Warranty to apply the Registration Card must be validly completed by You and returned, prior to the expiration of 3 months from the date of purchase.
2. You must provide proof of purchase.
3. Latronics recommends You keep your receipt as proof of purchase, should any difficulties arise concerning the return of your Registration Card.

Exclusions:

For the avoidance of doubt, the Latronics product warranties provided herein do not cover damage, malfunctions or service failures caused by, amongst other things:

- Unauthorized opening of the products, repair, alteration or substitution of nonstandard parts;
- Incorrect design and/or installation of 'balance of system';
- Acts of god, accident or similar cause;
- Failure to follow Latronics installation, operation or maintenance instructions;
- Abuse, misuse or negligent acts;
- Power failure surges, lightning, fire, flood, pest damage, accidental breakage, actions of third parties and other events or accidents outside Latronics' reasonable control and not arising from normal operating conditions;
- Suitably qualified personnel not carrying out all AC and DC permanent wiring in accordance with relevant wiring rules.

Products supplied by Latronics, or Latronics agents are supplied under the express condition that no responsibility is implied or accepted by Latronics for any damage to any appliance, equipment or property used in combination with the correct operation of a Latronics product.

All conditions and warranties expressed or implied by statute, common law, equity, trade, custom, usage, or otherwise howsoever are hereby expressly excluded to the maximum extent permitted by law. Where so permitted, the liability of Latronics for a breach of condition or warranty that cannot be excluded is limited (at Latronics option) to the replacement or repair of the goods or of acquiring equivalent goods or the cost of replacing or repairing the goods or of acquiring equivalent goods.

Latronics does not undertake any commitment to guarantee continuity of supply in the case of obsolescence. In addition, Latronics reserves the rights to change its standard product range or specification of any model subsequently without notice and no liability as a result of these occurrences will be accepted.

Our goods come with guarantees that cannot be excluded under the Australian Consumer Law. You are entitled to a replacement or refund for a major failure and compensation for any other reasonably foreseeable loss or damage. You are also entitled to have the goods repaired or replaced if the goods fail to be of acceptable quality and the failure does not amount to a major failure.

Part 2 - Returning a Latronics product for service under warranty;

If service is required contact your local supplier/installer or place of purchase for advice.
To Claim Under Warranty:

1. You should contact the Customer Care Centre on 1300 550 204. Product Model number and Serial number need to be readily available to enable prompt processing.
2. If, after investigation, the Customer Care Centre determines the product is or may be defective in material or workmanship and within the warranty period, they will issue instructions on how to proceed with return and shipping to Latronics.
3. When packaging a Latronics product for return appropriate measures must be taken by You to ensure the products are safely packed for transit. Products damaged in transit due to inadequate packaging will be void of warranty.
4. If the product manual has a Warranty Return Form included, this form should be completed and accompany products being returned.
5. If, as a result of further investigation by or on behalf of Latronics, such a defect is confirmed, then Latronics must, at its sole election, either repair or replace your Latronics product. Latronics will also, at their discretion, determine the most appropriate means to return any Warranty repairs (or replacements) to You in a timely manner.

Part 3 - General Information

Replacement of any part or labour involved in repairs will not have the effect of extending the original period of the Limited Warranty of the goods. Any faulty part replaced under Limited Warranty becomes the property of the Company for purpose of examination and claim under proprietary warranty.

Under these product warranties, Latronics is not responsible for and you hereby agree to bear any costs associated with removal, transportation or reinstallation of your Latronics products or any peripheral components in the balance of any system used in conjunction with Latronics products. Products returned to Latronics without prior authorisation will be returned to the sender at their expense.

All Warranty repairs are completed ex-factory to ensure

- Fast service turn around time
- Specialised, factory trained technicians
- All required components are available (except in the case of obsolescence)
- Thorough testing to all Latronics specifications
- Dedicated test equipment
- Upgrades/updates to latest Latronics standards/specifications (where applicable).

FAULT FINDING

Should the Inverter appear to be malfunctioning we suggest the following to eliminate any external problems:

1. Turn the Inverter "OFF" via the Circuit Breaker switch on the front panel.
2. Disconnect all AC wiring from the Inverter.
3. Disconnect DC battery leads from Battery. Clean all terminals by removing all grease/corrosion on both DC leads and battery terminals.
4. Ensure you have sufficient battery capacity at the nominal voltage (specified on the compliance label of your Inverter).

Please note: Use minimum 100AH Battery or the size of a substantial Car Battery.

5. Make connection directly to battery terminals and ensure all connections are tight.
6. Remove all other wiring from battery to ensure that the Inverter is the ONLY device connected to the battery bank.
6. Ensure battery voltage is within the correct limits as outlined in the section *INVERTER SPECIFICATIONS* of this manual. If you do not have a DC voltmeter or multimeter check the front panel for Overvolts and Undervolts LED'S.
7. Turn the Inverter ON via the Circuit Breaker switch on the front panel. Observe the lights on the front left of your Inverter. Refer to *INVERTER OPERATION* sections for explanation of Indicator lights.
8. Plug in various appliances and monitor the Inverters operation.

HELPFUL HINTS

- * Remember that the Inverter automatically starts when a load is applied.
- * Make sure leads and terminals are not corroded or faulty in any way.
- * Make sure the Inverter goes into STANDBY with no load switched on.
- * Make sure the Circuit Breaker is reset properly. If unsure switch OFF and ON again.

BATTERIES

BATTERY SIZING

It is important to match your battery size according to the power rating of the Inverter.

To ensure peak performance, it is important to choose the right battery for your Inverter. The battery size required will depend on the load and intended running time. Use this formula as a general guide:

Recommended Battery Size = Inverter rating in watts ÷ input voltage × 10

e.g. 1200W ÷ 12V × 10 = 1000Ah

Minimum Battery Size = Inverter rating in watts ÷ input voltage × 3

e.g. 1200W ÷ 12V × 3 = 300Ah

Do not use an undersized battery as this may result in an Inverter that does not start or that will rapidly discharge the battery and may cause damage to the battery.

MAINTENANCE

Battery terminals require frequent care and maintenance. Very high current (up to several hundred amps), is drawn by the Inverter when starting electrical motors and other high power appliances. We recommend an inspection of the batteries and the interconnecting cable connections once every 1-3 months or as recommended by the battery manufacturer.

1. Regularly check all connections; make sure they are always tight. Battery terminals are made of soft lead which will slowly compress over time eventually causing loose connections.
2. Check all connections are free of corrosion. Remove any corrosion and coat the terminals with Vaseline or grease to help prevent future corrosion.
3. Take specific gravity or SG readings of each cell using a hydrometer to check the level and performance of each battery. Alternatively a battery voltage reading for each cell will suffice, but may not be accurate for multiple batteries connected in parallel. Report any serious imbalance to your system installer or battery supplier for corrective action.

SAFETY

When working on batteries protective clothing and eye wear should be worn. Extreme care should be taken not to short circuit any battery terminals especially with tools. If in doubt have the work carried out by qualified personnel.

DIP SWITCH SETTINGS

Dip Switch Settings apply to all models from 1000W to 5000W inclusive.

In order to access these options you have to open the Inverter. Before altering the settings switch Inverter OFF, adjust the setting and switch Inverter back ON again. We recommend these adjustments be carried out by qualified personnel or your system installer.

SW1 Hz 50/60 Hz
ON = 50Hz (factory setting) OFF = 60Hz

SW2 SP Special

SW3 SP Special

SW4 SP Special

SW5 & SW6 UV Undervoltage Settings

SW5 OFF & SW6 OFF = (factory setting)

Setting		12V Value		24V Value		48V Value	
SW5	SW6	Disconnect	Reconnect	Disconnect	Reconnect	Disconnect	Reconnect
ON	ON	10.0	12.0	20.0	24.0	40.0	48.0
OFF	OFF	10.5	12.5	21.0	25.0	42.0	50.0
ON	OFF	11.0	13.0	22.0	26.0	44.0	52.0
OFF	ON	11.5	13.5	23.0	27.0	46.0	54.0

DIP SWITCH LOCATION

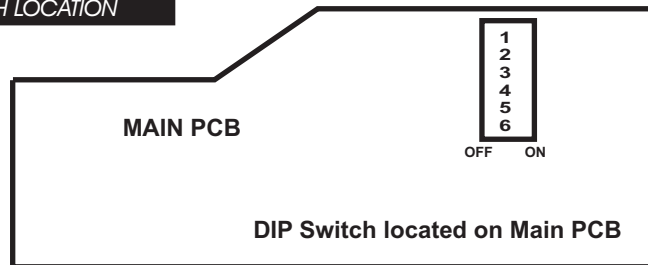

WARNING:

Due to dangerous voltages existing inside the unit, make sure the circuit breaker switch is turned off before opening the unit. These adjustments must be performed by a qualified and licensed personnel only.

DECLARATION OF CONFORMITY

Manufacturer:
Latronic Sunpower Pty Ltd
105 Grigor St West
Moffat Beach Industrial Park
Caloundra Queensland 4551
Australia

Declare that the IRM series of inverters conform to the requirements of following standards

EN61000-6-1
EN61000-6-3
EN55014
AS1044
EN60335-1
AS3100



And therefore conform to the regulations of the EC directives
Directive 2004/108/CE (EMC directive), Directive 2006/95/CE (low Voltage
Directive)
Date that CE marking was first affixed 2007

Also conforms to the RCM marking regulations for Australian emission standards

All products are manufactured with full traceability in accordance with the
Quality System Requirements of AS/NZS ISO 9002

Signed

William Pettit
Electrical Engineer
7th Feb 2009

RADIO FREQUENCY INTERFERENCE

Radio Frequency Interference (RFI) is a phenomenon that exists in modern society and is a problem in many areas of electronics. For Inverter users, RFI normally presents itself in the form of static and/or interference when listening to an AM radio and in unusual cases may interfere with TV reception.

Over the years Latronics has continued to invest significant time and effort in the reduction of RFI related emissions from the entire product range, so that they comply with the appropriate International and/or Australian Standards.

Even with this compliance, there are situations where RFI may still be a cause for concern, and can differ greatly from installation to installation. Accordingly, the following is a list of recommendations made to assist in the overall reduction of RFI.

1. *Separate DC and AC wiring.* Avoid running DC and AC cables in the same conduits and/or cable trenches. It is strongly recommended that DC and AC wiring be separated by the greatest distance possible. In extreme cases, the use of shielded conduit may be necessary.
2. *Minimize length of DC cabling.* DC cables can act as an aerial, therefore all such cables should be kept as short as is practicable. For best performance minimize DC cable length to Inverter and Batteries and if possible avoid the use of Auxiliary DC loads.
3. *240Vac Earth.* For household installations, it is recommended that a "good" Earth Stake is located as nearby the Inverter as is possible.
4. *AM and HF Radios.* These types of radio equipment inherently suffer from all forms of RFI, especially when the received signal level is weak. In such cases reception can sometimes be improved by relocation of the radio itself, alternatively the use of an appropriate external antenna and co-axial cable may be necessary. External antennas should be located in a manner that ensures maximum signal strength whilst affording the greatest possible distance away from the Inverter and batteries.
5. *Televisions.* TV signals are transmitted as FM waveforms. This type of signal fundamentally reduces the effects of RFI, therefore the use of a good antenna and feeder cable is normally sufficient to ensure quality reception. Locating the television as far as possible from the Inverter may also improve picture clarity.
6. *Mobile Installations.* Due to the limitations of this type of installation, the best results for the minimization of RFI are usually obtained by maximizing the distance between the Inverter and the Radio/Television.

AUTOMATIC RESET FEATURE

This feature is designed to restart the Inverter and maintain power in the event of an external fault. Should the Inverter shut down due to under voltage, over temperature or any fault condition it will attempt to reset every 8 minutes until the fault condition clears and normal operation resumes.

For overload shutdown the Inverter will only attempt 5 restarts. If the Inverter can not resume normal operation within 5 restarts, it will remain OFF until reset manually. This prevents continuous re-application of power to faulty appliances or wiring.

For under voltage shutdown the Inverter will restart when the battery voltage reaches the reconnect value as shown in the table opposite.

AUTOMATIC AC TRANSFER SWITCH (Option code - KX)

Eliminate the need to manually switch your power source between Inverter and Auxiliary AC. The Transfer Switch automatically senses Auxiliary AC power and switches the output between Inverter and Auxiliary AC accordingly.

Take the hassle out of wiring a changeover switch between Inverter and Auxiliary AC. Have this option fitted to your IRM series Inverter to simplify your power system wiring. Simply connect the Auxiliary AC to the hardwire terminals, its that easy!

Features

- * Available exclusively to the IRM series from 500W to 5000W models
- * No Break changeover time of 0.02 second (< one cycle)
- * Double pole relay switching both active and neutral
- * Minimise and simplify system wiring

SYSTEM BLOCK DIAGRAM

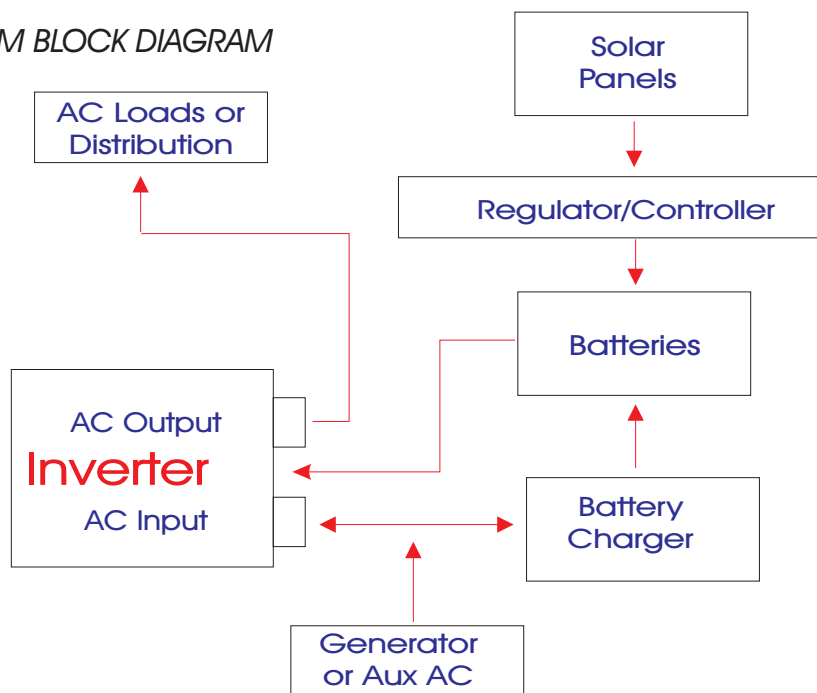

* Installation of system components and associated interconnecting wiring, should be performed by qualified and licensed personnel only.

WIRING FOR MULTIPLE REDUNDANCY SYSTEMS

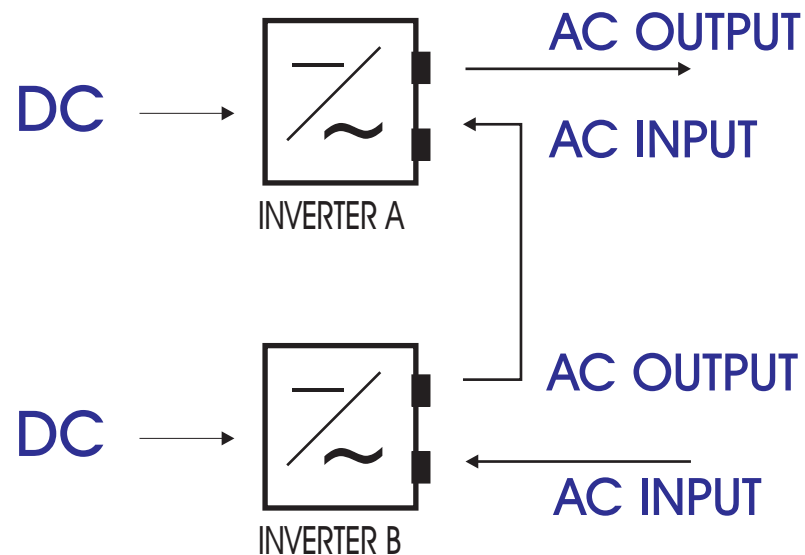

Dual Inverter Backup Systems - AC Output will be available as long as Inverter A or Inverter B is operational.

Mains with Inverter Backup - Inverter B would be replaced via mains AC and Inverter A will then backup the mains.

Mains with Dual Inverter Backup - Mains AC is connected to the AC input of Inverter B.

Ultimately there is no limit to the number of units that can be connected.

MISCELLANEOUS OPTIONS

Inverter Alarm - (option. Code L)

Voltage free contacts, isolated relay contacts NO, NC & COM. Inverter AC output voltage is monitored and relay changes state if Inverter output is not present. General fault alarm for any of the shut down conditions; DC undervoltage, DC overvoltage, Overload, Overtemp.

**Note - Power saving/standby mode is disabled for this option.*

Transfer Alarm - (option. Code O)

Voltage free contacts, isolated relay contacts NO, NC & COM. AC Transfer Switch is monitored and relay changes state when AC Transfer Switch changes between Auxiliary AC & Inverter AC.

**Note - Power saving/standby mode is disabled for this option.*

Psophonometric Noise - (option. Code J)

For sensitive telecom applications where low DC noise is required. Complies to noise standard ETS 300 132-2.

Anderson Connectors

As an alternative to Battery Lugs, Anderson Connectors offer a quick and simple method of polarised connection and reconnection.

Power Outlets

Various International and Australian sockets are available as alternative to the hardwire facility for AC output connections.

AUTOMATIC AC TRANSFER SWITCH *Continued.*

The Automatic transfer switch option is available for all IRM Series inverters. It offers further protection to connected appliances from Generator voltage fluctuations and ensures a more stable AC supply.

Upon the starting of a Generator the output voltage will rise and stabilise as the Generator speed increases. Once the Generator voltage is within the required limits the timer provides a short delay before switching the Generator power to the AC output. This ensures the Generator is warmed up and the output voltage is stable. The Generator output voltage is continuously monitored and if it is outside the set limits the transfer switch will switch back to the Inverter. This prevents problems due to low voltage and overvoltage surges, which can harm appliances.

On Delay Timer - ensures the Generator has warmed up and the output voltage is stable before the transfer switch is activated.

Voltage Interlock - monitors the Generator output voltage. If too high or too low the Transfer Switch reverts back to the Inverter output until the generator output re-stabilises.

Versatile - selectable voltage levels and time delay.

Note: Highly recommended for Generators with large fly wheels that ramp up and down slowly at start up and shut down.

Settings are adjustable via Jumpers located on the inside of the Inverter on the blue circuit board.

Jumper	Voltage Window	Time Delay
1	170V - 280V	5 sec
2	210V - 270V	5 sec
3	170V - 280V	30 sec
4	210V - 270V	30 sec

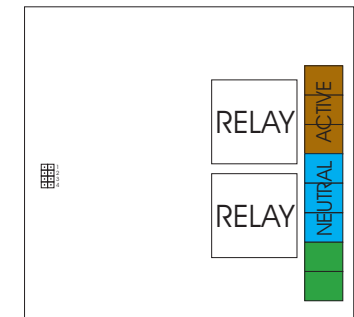

ENSURE POWER IS DISCONNECTED BEFORE ADJUSTING JUMPERS
To be adjusted by qualified personnel only!

Available for as an option for all IRM series inverters

IRM SPECIFICATIONS

<i>MODEL NO.</i>	<i>DC INPUT</i>	<i>POWER</i>
IRM512	12V	500W
IRM624	24V	600W
IRM648	48V	600W
IRM696	96V	600W
IRM6120	120V	600W
IRM1012	12V	1000W
IRM1224	24V	1200W
IRM1248	48V	1200W
IRM1296	96V	1200W
IRM12120	120V	1200W
IRM1512	12V	1500W
IRM1824	24V	1800W
IRM1848	48V	1800W
IRM1896	96V	1800W
IRM18120	120V	1800W
IRM2012	12V	2000W
IRM2324	24V	2300W
IRM2548	48V	2500W
IRM2596	96V	2500W
IRM25120	120V	2500W
IRM3024	24V	3000W
IRM3548	48V	3500W
IRM3596	96V	3500W
IRM35120	120V	3500W
IRM5048	48V	5000W

INVERTER WIRING & CONNECTIONS

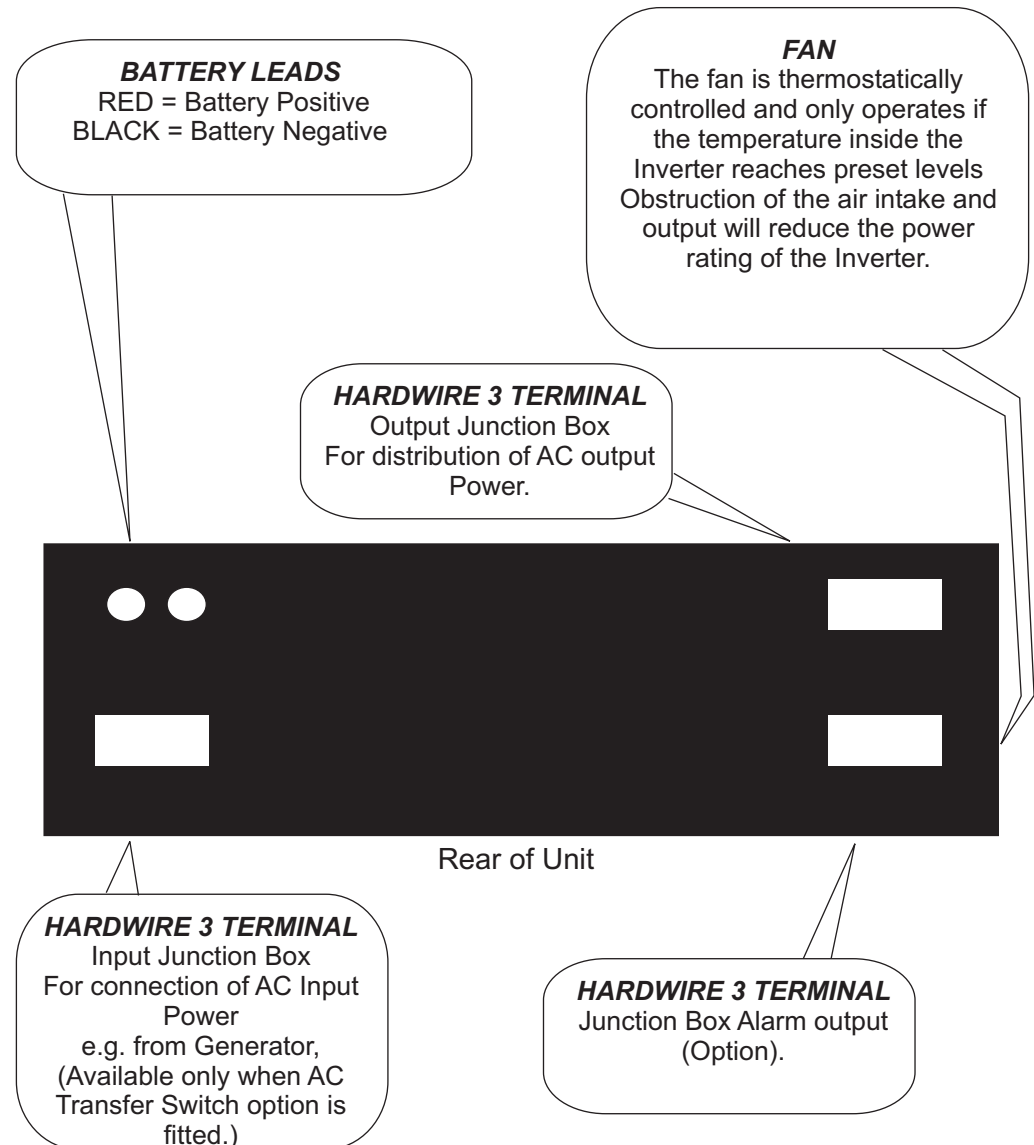

SAFETY

Inverter Isolation and Safety

- * All Latronics Inverters have an isolation rating of 3500V between AC and DC via the toroidal transformer, which ensures extremely safe and risk free operation.
- * All the switching electronics and control circuitry are on the DC input.
- * The Circuit Breaker ensures that when the Inverter is switched OFF, it is isolated from the battery supply.

Please refer to relevant Australian Standards for safety procedures.

AC WIRING

- * Make sure the Inverter is switched OFF before working on the mains wiring. Turn the Circuit Breaker switch into OFF position.
- * The active and neutral of the 240V AC output are electrically isolated from the battery negative, battery positive, and Earth connections.
- * The Inverter AC output is connected directly to the transformer output winding.
- * Latronics Inverters have the AC output (active and neutral) floating with respect to the DC and Earth. The Earth connection is connected to the case only. This configuration provides the highest safety and most flexibility for installation wiring.
- * Latronics Inverters are suitable for MEN connection.
- * The Earth is connected internally to the Inverter case.

Ensure that power will never be fed into the Inverter AC output Junction Box from the Mains or Generator.

This would result in the destruction of the unit and will not be covered by warranty.

WARNING:

The Inverter output is just as lethal as normal mains electricity, thus it is important that all AC wiring complies with the requirements of the relevant wiring standards, (AS 3000).

Any work carried out on AC/Mains wiring is to be performed by Qualified and Licensed personnel only.

Features

- ✱ Pure Sinewave Waveform
- ✱ Massive Inrush and Overload Capability
- ✱ Rugged Construction
- ✱ Designed and Manufactured in Australia
- ✱ 3 year Warranty
- ✱ DC Circuit Breaker/ Battery Isolator Switch
- ✱ High Efficiency Toroidal Transformer
- ✱ Galvanically Isolated

Specifications

Input Voltage	12, 24, 36, 48, 72, 96 & 120 Others available
Input Voltage Range	-20% to +45% of Nominal
Output Waveform	True Sinewave <4% THD
Output Voltage	230V +/- 4% Standard 110V +/- 4% Option
Output Frequency	50/60Hz +/- 0.1%
Crest Factor	>4
Overload Capacity	300% 5 Seconds (all models) 120% 30 Minutes (110% 12V models)
Operating Temperature	-10°C to +50°C (can be extended)
Cooling	Thermostatically Controlled Fan
Power Factor	All Conditions
Peak Efficiency	90% to 94% Model Dependent
DC Connections	Heavy Duty Low Loss Battery Leads
AC Connections	Screw Terminal Junction Box
Standards	AS/NZS 3100, EN55014, EN61000-6-1, EN6100-6-3, AS 1044 EN60335-1 & RCM
Protection Circuitry	Full Electronic Protection against Overload, Overtemperature, Short Circuit, Battery Over & Undervoltage
Dimensions	19" Rackmount 3U x 350mm Deep All Models

INVERTER OPERATION

When the Inverter is switched on all 3 LED'S light up for 1 second while the microprocessor performs a start up and system check procedure.

Over temp./Over load (Red LED)

If the internal temperature exceeds safe operating limits of the components for more than five seconds, the Inverter will shut down in Over temp with this LED on continuously. Allow 5 minutes for the Inverter to cool and reset the unit. If the APPLIED load demands more current than the Inverter can safely supply for more than 5 seconds, the Inverter will shutdown in Over load and this LED will flash.

POWER INDICATOR (Green LED)

This LED flashes when in Standby mode (i.e. no loads connected). When a load is applied the LED will illuminate continuously to indicate that 230V AC is being supplied.

**CIRCUIT BREAKER
BATTERY ISOLATOR
ON/OFF Switch**

The circuit breaker is designed for ease of operation and safety. If the Inverter shuts down due to Overload, Undervolts or Overvolts it can be reset by turning the Circuit Breaker OFF, waiting 10 seconds (or until LED goes out), then turning it on again.

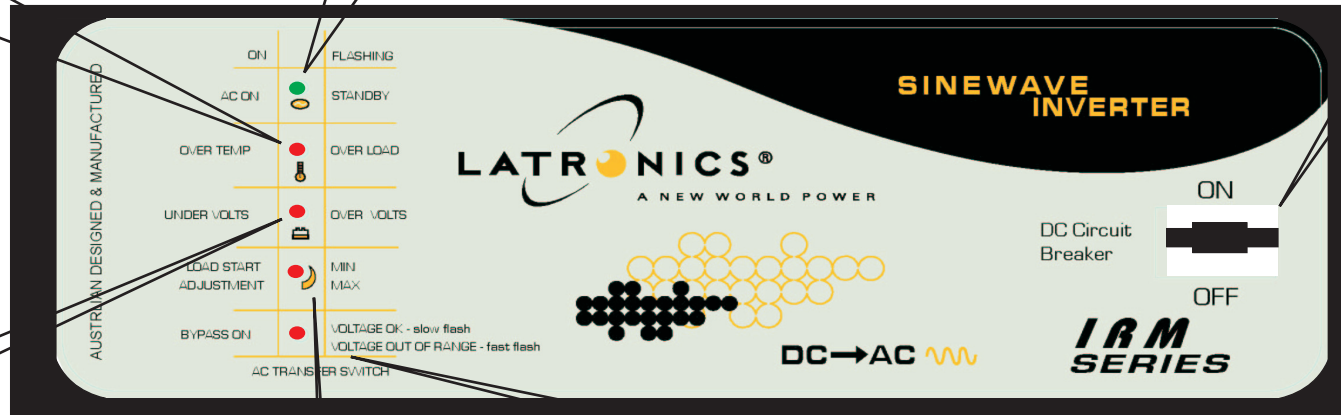

Undervolts/Overvolts (Red LED)

In order to protect the battery the Inverter will shutdown after 5 seconds if the battery voltage falls below its limit, (Undervolts), or exceeds the maximum, (Overvolts), as specified in the Electrical Specifications table. For Undervolts the LED will remain on continuous, while for an Overvolts situation the LED will continue to flash.

AutoStart Sensitivity Adjustment

The screwdriver adjustment slot permits the operator to adjust sensitivity between 0- 20W. Due to lengthy 240V AC cables the Inverter may sense fake loads. To combat this, turn the control clockwise. Alternatively turning the control in the opposite direction increases sensitivity. Turning the control fully anti-clockwise will disable the Auto Start feature and the Inverter will remain constantly ON.

TRANSFER SWITCH INDICATOR

Inverter is secondary

OFF = No AC input present
 Fast flash = AC input voltage out of range
 Slow flash = AC input voltage OK and delay timer ON - 1 flash per second
 ON = AC input switched through to output

Inverter is primary

OFF = No AC input present
 ON = AC input is available